

Lecture #1

Intro

Aims:

- Get to know each other (teachers & participants)
- Get an overview on the course and understand what is expected from you

Your BIOENG-421 team



Tianhao
Li



Eddy
Leardini



Christoph
Merten

Bioinstrumentation is fun
Bioinstrumentation is HANDS-ON!
Bioinstrumentation is a good opportunity
for commercializing lab innovations!

Lab on a Chip

Dynamic Article Links ▶

Cite this: *Lab Chip*, 2012, 12, 4677–4682

www.rsc.org/loc

TECHNICAL INNOVATION

Fragmentation of DNA in a sub-microliter microfluidic sonication device†

Qingzong Tseng,^a Alexey M. Lomonosov,^b Eileen E. M. Furlong^a and Christoph A. Merten^{a*}

Received 23rd May 2012, Accepted 4th September 2012
DOI: 10.1039/c2lc40595d



diagenode

1st external licensing



Design and construction of a microfluidics workstation for high-throughput multi-wavelength fluorescence and transmittance activated droplet analysis and sorting

Jatin Panwar^{1,2,3}, Alexis Autour^{1,2,3} and Christoph A. Merten^{1✉}

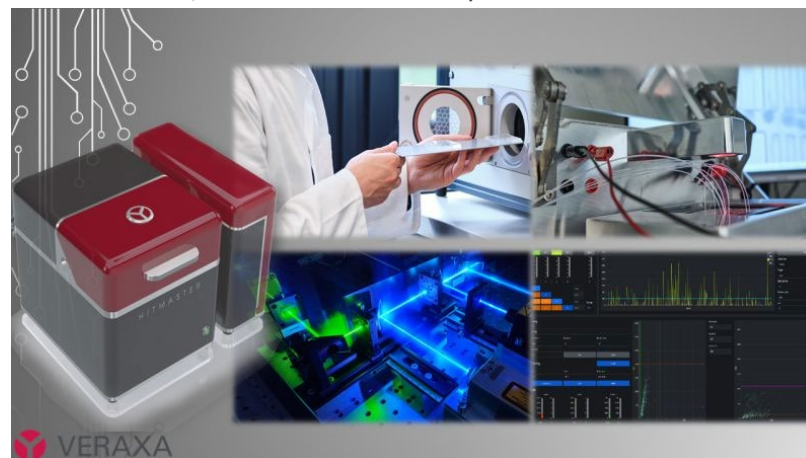

1st startup



A microfluidic Braille valve platform for on-demand production, combinatorial screening and sorting of chemically distinct droplets

Ramesh Utharala^{1,7}, Anna Grab^{1,2,7}, Vida Vafaizadeh^{1,3,7}, Nicolas Peschke¹, Martine Ballinger^{1,4}, Denes Turei^{1,5}, Nadine Tuechler¹, Wenwei Ma¹, Olga Ivanova⁵, Alejandro Gil Ortiz¹, Julio Saez-Rodriguez^{5,6} and Christoph A. Merten^{3✉}

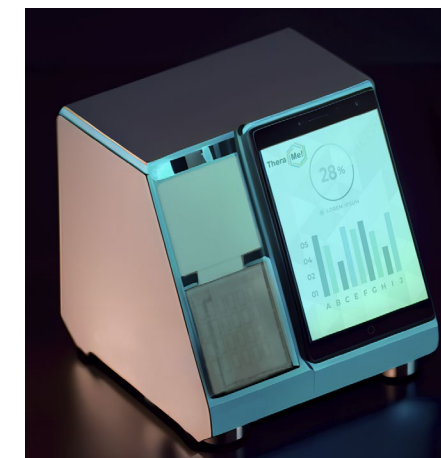

2nd startup

Introduction of course BIOENG-421 participants

All students to introduce themselves. Describe YOUR personal background and expectations!

What we expect from you:

Teaching goals:

- **Getting an overview on common lab instrumentation** and underlying measurement approaches (**briefly present one bio-instrument of your choice, group task, max 10min + Q&A - 30% of your grade**)
- **Preparing a blueprint of an instrument** for high throughput fluorescence analysis of microfluidic droplets – **prerequisite for all below tasks, group task, to be approved by the teachers**)
- **Building an instrument** for high throughput fluorescence analysis of microfluidic droplets, record data enabling to determine e.g. enzyme concentrations, implement feedback loops
 - (**write a short report, group task, max 10 pages – 20% of your grade**)
 - (**give a presentation, group task, max 20min + Q&A – 30% of your grade**)
 - (**Q & A session, individual task, max 10min – 20% of your grade**)

THIS IS NOT A FEEDBACK SESSION OF YOUR WORK!

Supporting materials are available on Moodle straight from the start, including a template case study and a *Nature Protocol* on how to build a microfluidic workstation

Lectures (PHH 331)	Date & Topic	Details	Practical (location as color coded on next slide)
1	12.09 General Intro	Get to know teachers, TAs, students and aims of the course	16.09 Measure temperature using thermistor (using M&A explorer) TL
2	19.09 Lecture LabVIEW TL Group formation (A-F, 3 students, each)	Some first basic steps in LabVIEW programming	23.09 Brief intro into LabVIEW thermistor program (input and output) TL
3	26.09 Case study FACS, similarities and differences to droplet microfluidics Selection of case study topics	1.) Property to measure? 2.) Device? 3.) Working principle? 4.) Alternatives?	30.09 Preparation of bioinstrument case study
4	03.10 Groups A-C presenting case study (D-F not present)		07.10 Tour through LBMM workstation labs, intro into Nature Protocols (Groups A-C)
5	10.10 Groups D-F presenting case study (A-C not present)		14.10 Tour through LBMM workstation labs, intro into Nature Protocols (Groups D-F)
6	17.10 Lecture optics Homework: Students to prepare one laser/PMT blueprint FP	Mirrors, filters, microscope setup, lenses, etc.	21.10 Holidays
	25.10 Holidays		28.10 Build workstation optics 1
7	31.10 Lecture electronics	FPGA, PMTs, amplifier, function generator	04.11 Build workstation 1 optics 2
8	07.11 Intro into enzyme concentration measurement experiment (kinetics, etc.) + task FP	Enzymes, kinetics, practical task	11.11 Build workstation electronics
9	14.11 Intro to droplet analysis software (LabVIEW) TL	Software similar to Thermistor program, pdf on installation	18.11 Build workstation software: Add output LED (mimicking sorting trigger) into analysis software
10	21.11 Fundamentals of microfluidics and microfluidic chips	Flow at the microscale, microfluidic chips (manufacturing), droplet microfluidic modules	25.11 Run microfluidic experiments, e.g. determine concentration of MMP in droplets
11	28.11 Prepare presentation		2.12 Sorting Demo on LBMM workstation1 (Groups A-C)
12	05.12 Groups D-F presenting results (A-C not present)		09.12 Sorting Demo on LBMM workstation1 (Groups D-F)
13	12.12 Groups A-C presenting results (D-F not present) 15.12 Submit report (all!)		16.12 – TUESDAY! - Individual Q & A sessions (10min, Groups A-C)

Green shading: Single seminar/practical with all 18 students
Red shading: Individual seminar/practical with only 6 students required (= 3 sequential 90min slots, 4.5h in total)

Practical sessions

PHH 331

MED 2 1117

**Pick up: MED 2 1117
Work: LBMM labs**

ALL 8.15am

Groups A & B: 8.15am

Groups A or D: 8.15am

Groups C & D: 10.15am

Groups B or E: 9.30am

Groups E & F: 12.15pm

Groups C or F: 10.45am

To avoid confusion: ALL Friday lectures will be held in PHH 331!

BIOENG-421 Basics in bioinstrumentation

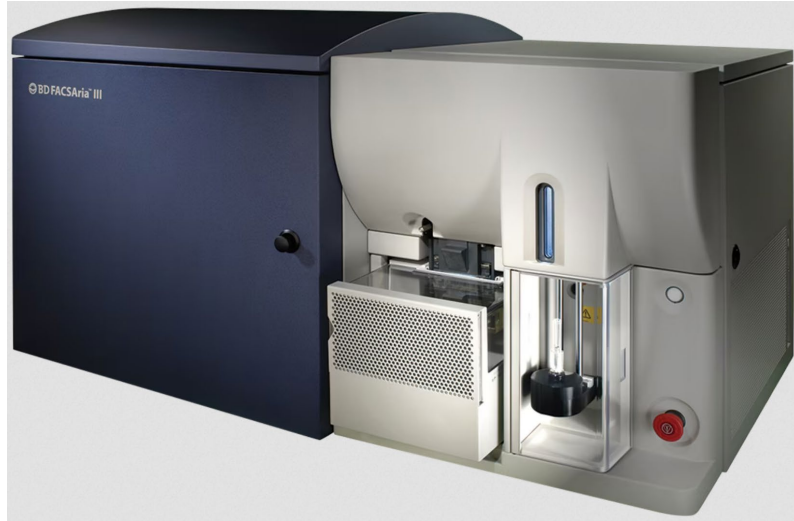

Aim 1: Understand how common bioinstruments work

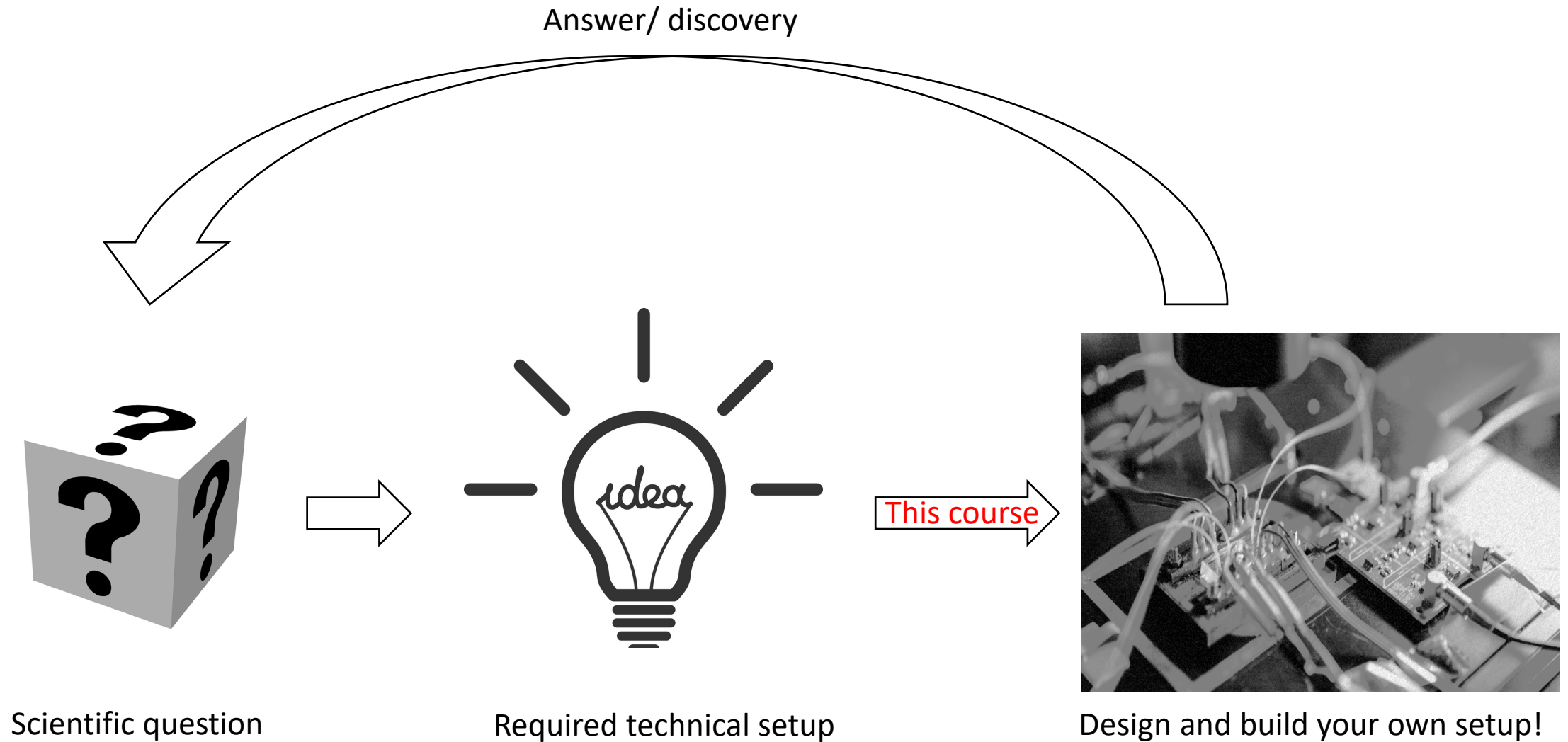

Aim 2: Develop an understanding on how to build new bioinstruments for addressing questions that cannot be answered with existing devices

What bioinstruments do you know?

Can you name some biological breakthroughs that were based on the development of new hardware technology?

What bioinstruments do you know?

Can you name some biological breakthroughs that were based on the development of new hardware technology?

(e.g. PCR – [Nobel Prize 1993], NGS, Single cell analyses, X-ray crystallography, Cryo EM)

Case study (max 10min + Q&A)

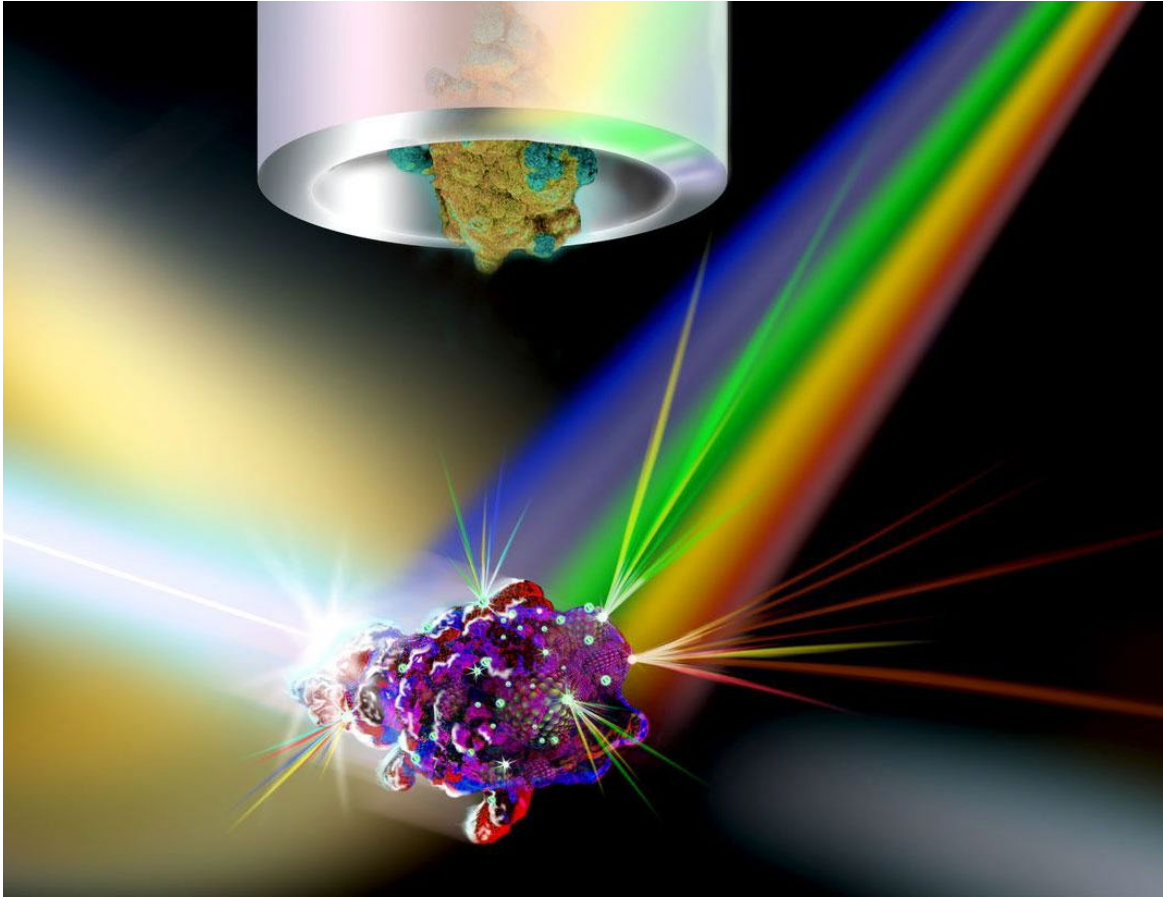

<https://umanitoba.ca/health-sciences/research/flow-cytometry>

Briefly present one bio-instrument of your choice, group task - 30% of your grade

What biological property is being measured? Is it measured directly or via “reporters”?

How does the instrument look like?

What is the working principle/ experimental setup?

What data is being processed (input/output in analogy to our temperature measurements)

Q&A

Blueprint of your instrument

Preparing a blueprint of an instrument for high throughput fluorescence analysis of microfluidic droplets – **prerequisite to pass**

Your task: Simplification of the Panwar & Autour Nature Protocols 2023 setup, including only one laser and one PMT and only a virtual feedback rather than active sorting

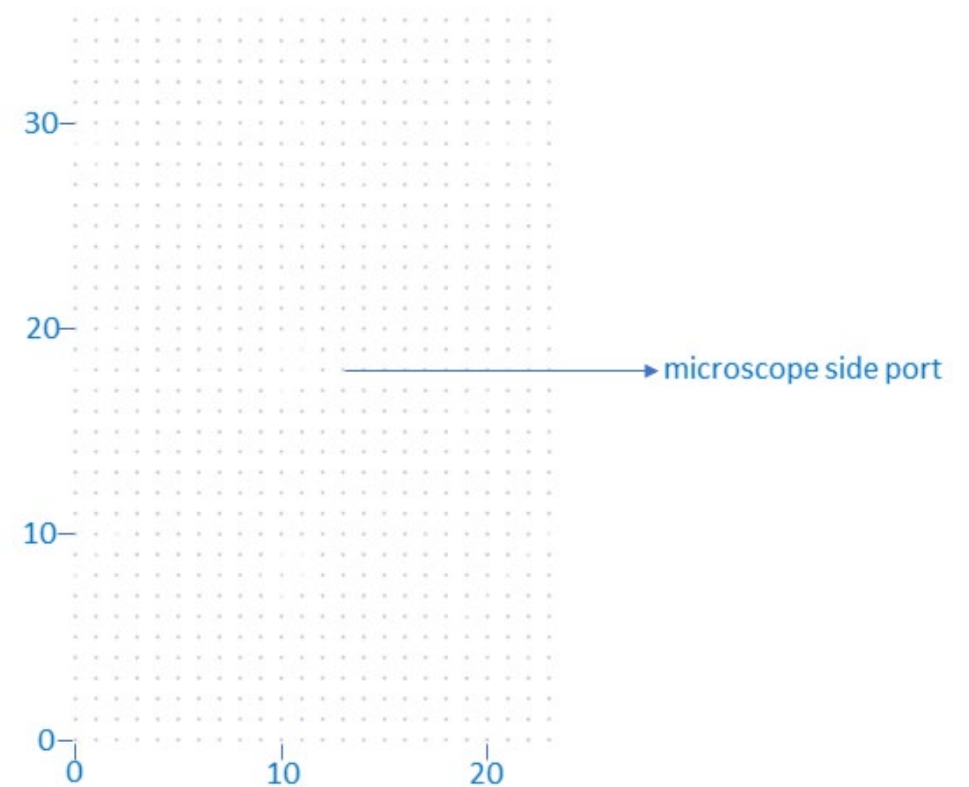
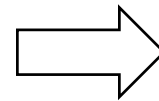
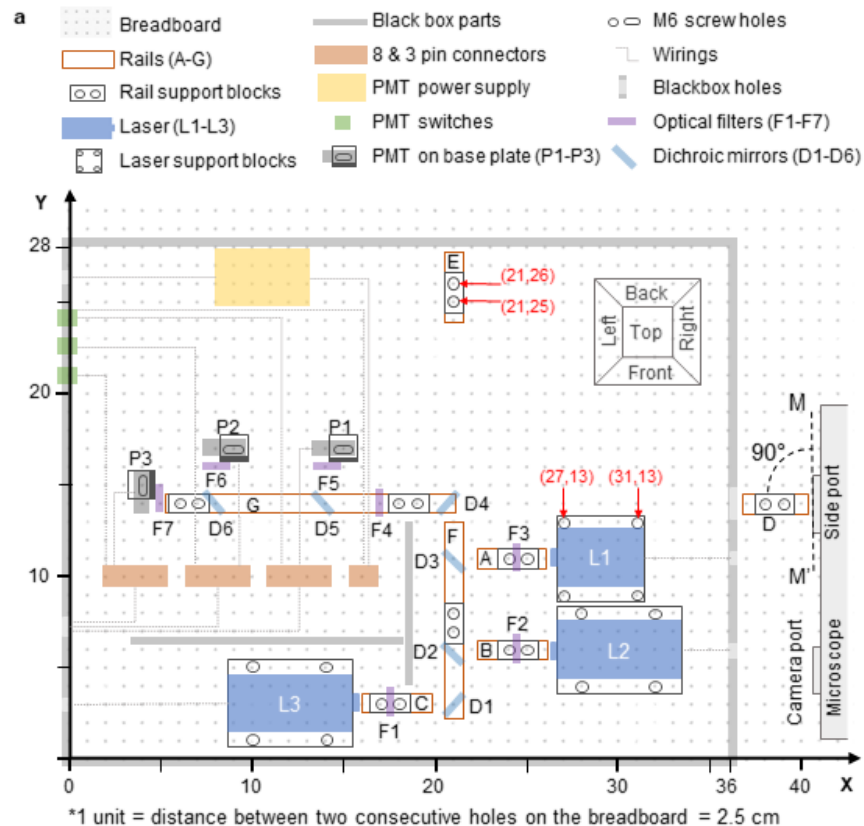

LBMM 3 channel fluorescence detection

BIOENG-421 single channel fluorescence detection

Build your instrument, collect data and present results

- Building an instrument for high throughput fluorescence analysis of microfluidic droplets, record data enabling to determine e.g. enzyme concentrations, implement feedback loops
 - (write a short report, group task, max 10 pages – 20% of your grade)
 - (give a presentation, group task, max 20min + Q&A – 30% of your grade)
 - (Q & A session, individual task, max 10min – 20% of your grade)

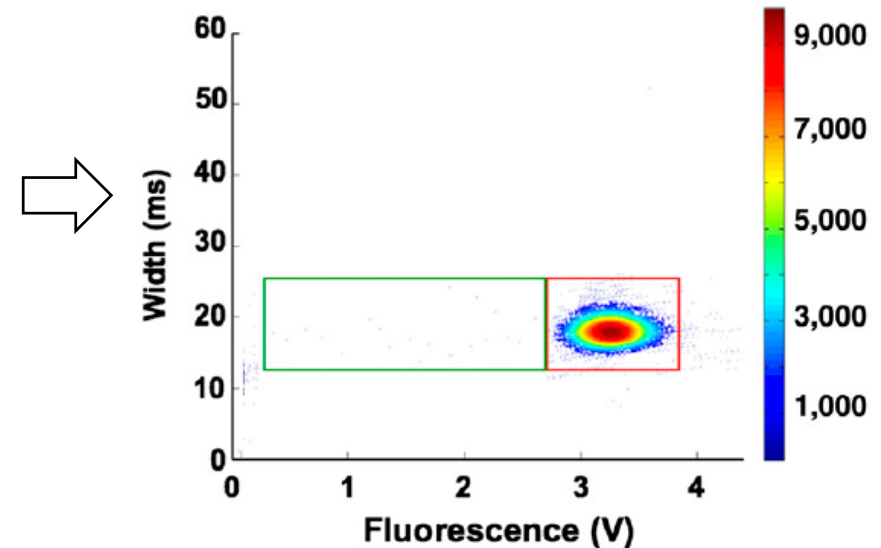
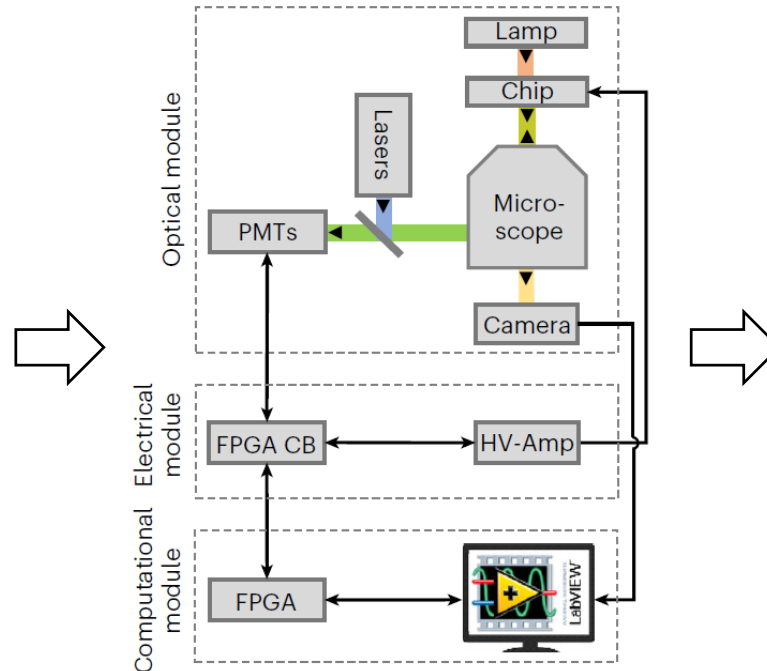
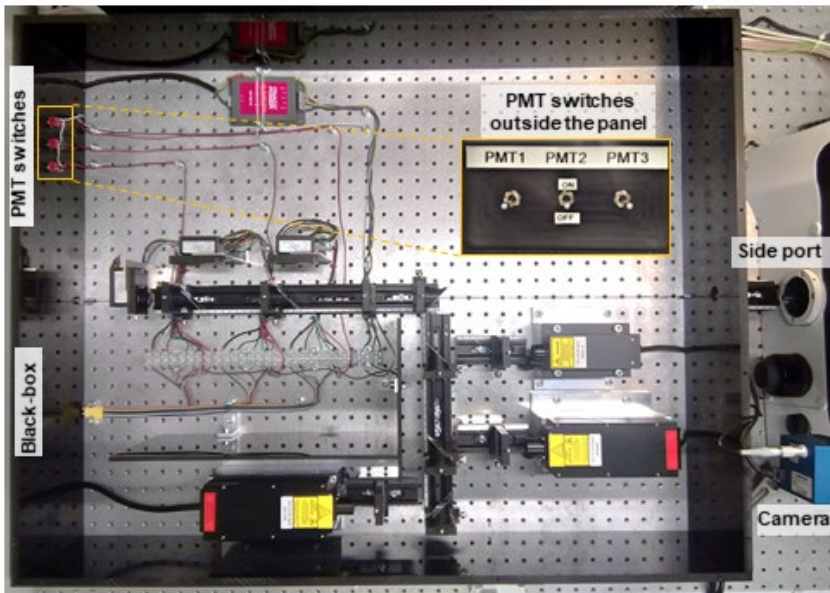

Recommended reading & Moodle resources



Design and construction of a microfluidics workstation for high-throughput multi-wavelength fluorescence and transmittance activated droplet analysis and sorting

Jatin Panwar^{1,2,3}, Alexis Autour^{1,2,3} and Christoph A. Merten¹✉

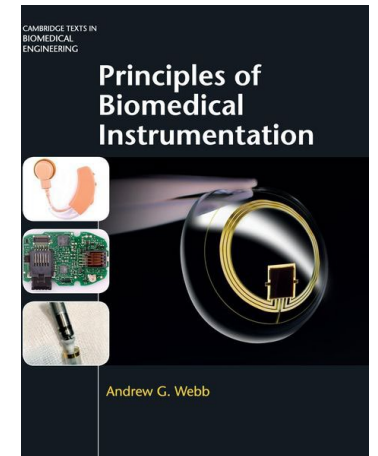
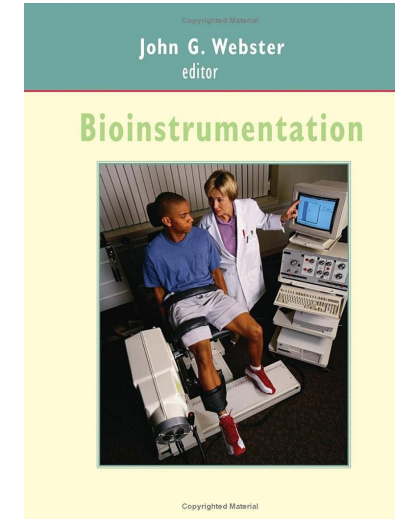
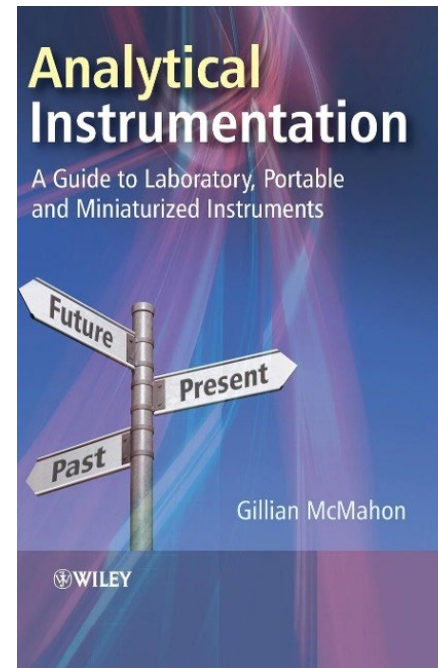

Tasks until next lecture

Practical task: Measure your body temperature using a thermistor

Questions?

